



EPS (Expanded Polystyrene)

*Lighter. Stronger. Smarter.*

The thought and consideration we put into our product goes well beyond design.

## Installation Guides

### 1. Preparation of surfaces:

- Clean all surfaces. Wall surface and moulding shall be clean and dry.
- All surfaces shall be a minimum of 38° Fahrenheit (3.3° Celsius) or higher.
- Building surface shall be level, plum and ready to accept stucco mouldings.
- Installer shall contact general contractor responsible for work if building surfaces are not level, plum and clean before application of stucco mouldings.
- All mouldings shall be cut and dry fit prior to applying any adhesive materials.

### 2. Apply adhesive to the back surface of stucco moulding. Use approved adhesive such as PL premium or equal for the purpose of adhering to the substrate (building surface).

- We recommend using Acro-coat cement mix when joining moulding to moulding. **When applying to Stucco, use Flexcoat adhesive and approved mesh when joining moulding to moulding.**
- When joining moulding at miter joints, remove 1/4" deep x approx. 3/8" wide of foam before applying Acro-coat material to allow for adequate adhesion. Wipe away all excess material when miter is joined together.
- Apply approved adhesive using a 3/8" notched trowel. Adhesive shall be applied vertically and all excess adhesive shall be wiped clean prior to installation.

### 3. With adhesive applied, push moulding into place after providing all level and plum guide lines. You should use mechanical fasteners to hold mouldings while adhesive cures.

### 4. See detail for mechanical fastener if required, provide pre-drilled holes prior to using fastening nail.

### 5. Clean all surfaces of adhesive prior to adhesion during curing period.

### 6. After adhesive cures, apply caulking at all joints between mouldings and building substrate. Provide caulking between joined mouldings.

### 7. Allow all materials to cure and dry before painting with elastomeric masonry, stucco & brick paint.

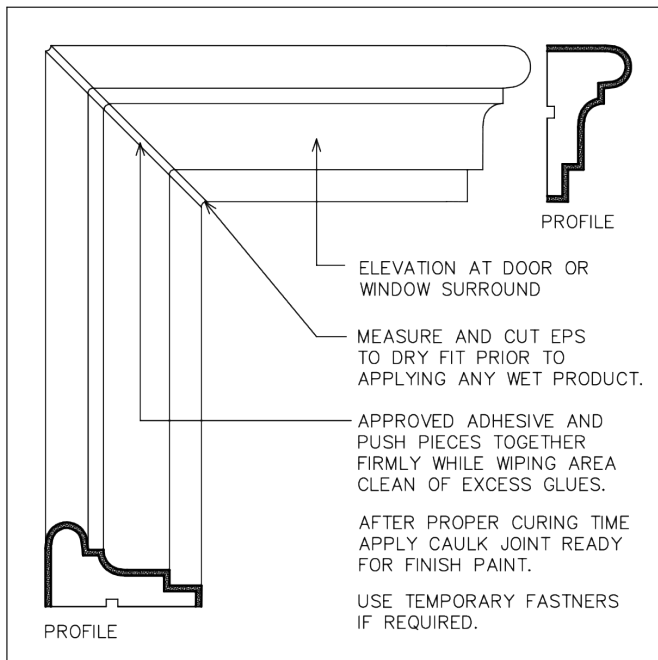

## Stone

**Add 2" thickness to stock sizes to accommodate for stone installation.**

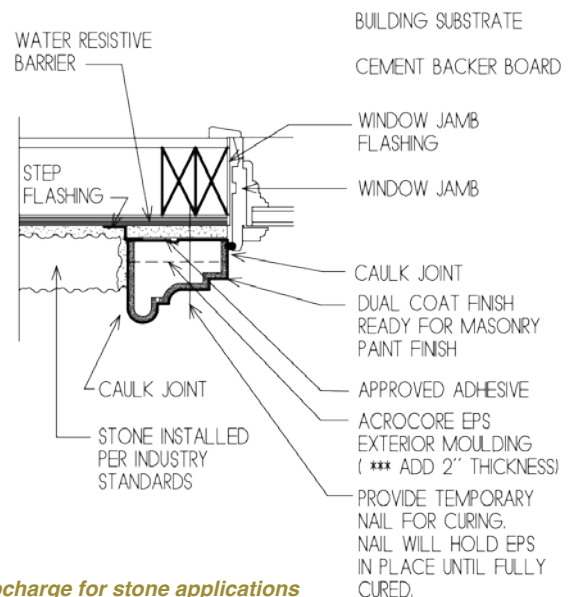

**Note:**  
20% upcharge for stone applications due to 2" added depth of mouldings.



**EPS (Expanded Polystyrene)**

*Lighter. Stronger. Smarter.*

The thought and consideration we put into our product goes well beyond design.

## Installation Guides

### Stucco

*All stock sizes apply.*

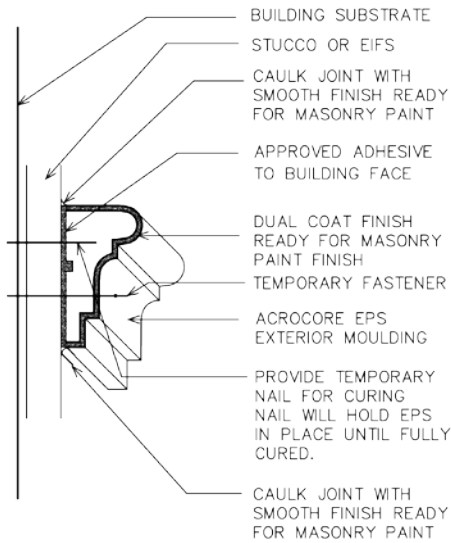

### Brick

*All stock sizes apply.*

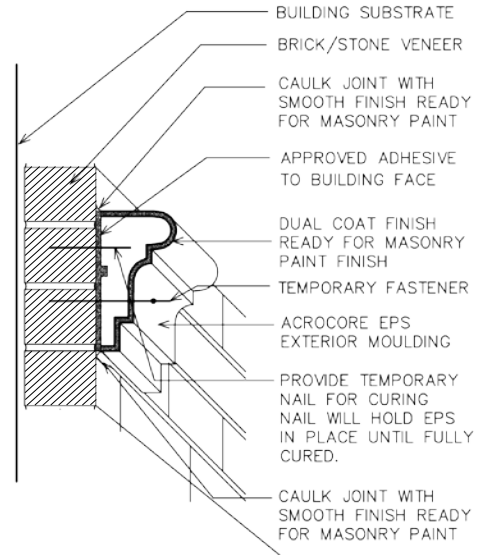

### Vinyl or Aluminum Siding

*Add 1" - 2" thickness to foam if required depending on siding thickness.*

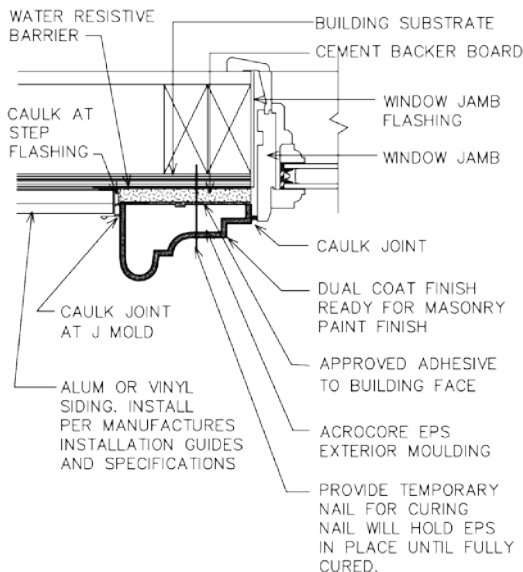

### Cement or Wood Siding

*Add 1" - 2" thickness to foam if required depending on siding thickness.*

