

# Flexboard Technical Guide

**A bendable substrate material that can be formed first and laminated last**

*Patent #5,618,601; #5,232,762; #5,824,382*

## Doors

*Larger radius and small doors are easily made with the use of Timberflex or Flexboard.*

*For larger size doors or smaller radius doors we recommend the use of Kerfkore, as it is easier to use for these size items.*

### Vacuum Method - Figure 1

Doors can be produced with many methods. We recommend where possible to form using the simple vacuum press method. This will require a form that can be easily made from the Kerfkore line of products.

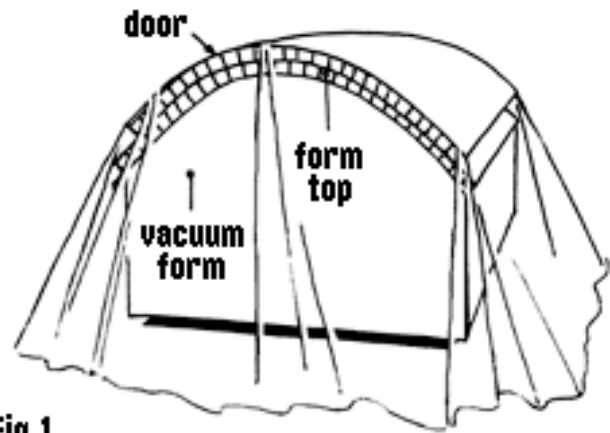

**Fig 1.**

1. Cut the Timberflex or Flexboard to the desired size of the formed door. This is best done by having a cross-section drawing of the door and taking a small strip of the product to determine the needed width. Note that the Timberflex or Flexboard face side can be placed on the inside or outside of the door as needed.
2. A back should be cut slightly oversized to allow for trimming once the door is formed. This back should be a material similar to the face when possible. If this is not possible then select a material that is close to or equal in strength to the face.
3. A standard PVA glue should be applied to the inside of the back. This will be placed on the form and the Timberflex or Flexboard will be positioned over the back allowing the back to extend past the face on all edges. The panel should be pressed for the time recommended by the glue manufacturer.
4. Once the panel has cured, the back edges can be trimmed by use of a hand router or saw.
5. The top and bottom edges can then be covered with the desired material to cover the open kerfs. This can also be done to the vertical edges if desired. The face and back can

then be covered with the desired materials to give you a finished door. Any machining for concealed hinges or hardware can now be done.

### Non-Vacuum Method - Figures 2 & 3

1. Cut the Timberflex or Flexboard to the desired size of the formed door. This is best done by having a cross-section drawing of the door and taking a small strip of the product to determine the needed width. The Timberflex or Flexboard face side will be placed on the inside of the door.

2. A face should be cut slightly oversized to allow for trimming once the door is formed. This face should be a material similar to the Timberflex or Flexboard when possible. If this is not possible, then select a face that is close to or equal in strength to the material.

3. The form for this process should be made of ribs that will provide the radius required to produce the correct size door. Remember that these ribs must allow for the thickness of the Timberflex or Flexboard, as this will be the inside radius of the door. You will need a support rib about every 6 inches to provide the needed support. (Fig. 2)

4. Place the Timberflex or Flexboard face down on the form, making sure you have a rib or support where the edges of the door are placed.

5. Cut the face material so you will have approximately 1/2" overhang on all edges.

6. Spread a moderate amount of PVA glue on the rib side of the Timberflex or Flexboard and the back side of the face material.

7. Use a scrap piece of Timberflex or Flexboard to place over the face to help distribute the pressure evenly over the door. Strap this assembly in place with belt clamps.

The use of a scrap piece of wood at the vertical edges of the assembly is recommended to help provide adequate pressure on these critical edges. Allow the glue to dry as recommended by the manufacturer. The overhang edges can be trimmed using a hand router. (Fig. 3)

fig. 2

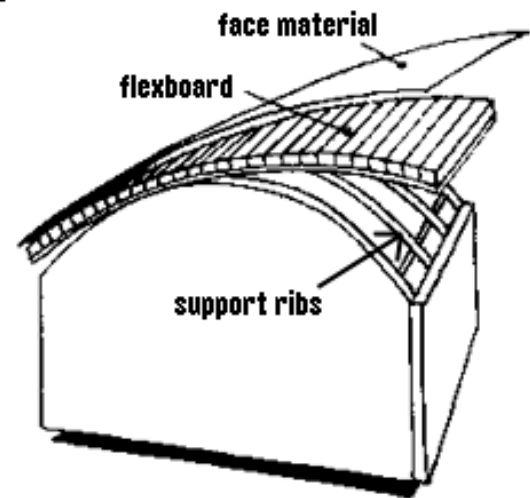
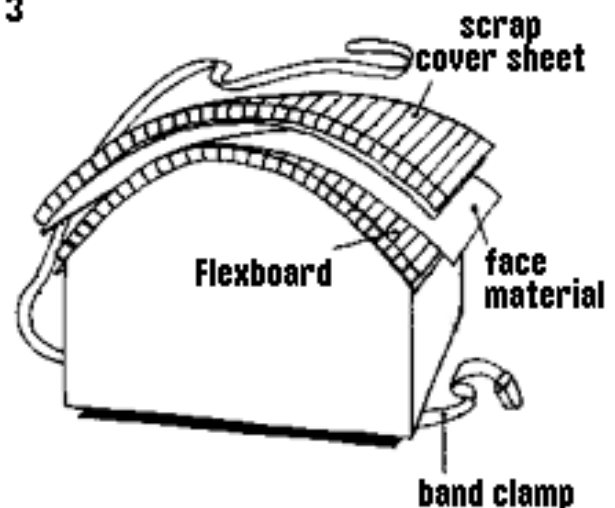

fig. 3



8. The top and bottom edges can then be covered with the desired material to cover the open kerfs. This can also be done to the vertical edges if desired. The face or back can then be covered, if needed, with the desired materials to give a finished door. Any machining for concealed hinges or hardware can now be done.

### Attachment Methods

*Timberflex and Flexboard can be attached with the use of glue and staples to a framework*

This framework should consist of horizontal ribs to attach the material. In most applications at least three ribs are recommended. Where the height of the framework is over 4' it is recommended that a horizontal support rib be used every 15 to 18 inches to provide the necessary support.

(Fig. 4 and Fig. 5)

Vertical support ribs are not needed to attach the Timberflex or Flexboard. Vertical ribs should only support and position the horizontal ribs. It is recommended that any vertical ribs be set back slightly from the horizontal ribs so they will not interfere in the forming of the material. Only attach to a flush vertical rib when forming a seam.

It is fine to use a hot melt type of glue on the inside of the framework after the Timberflex or Flexboard has been attached to help further secure the material to the frame.

fig. 4

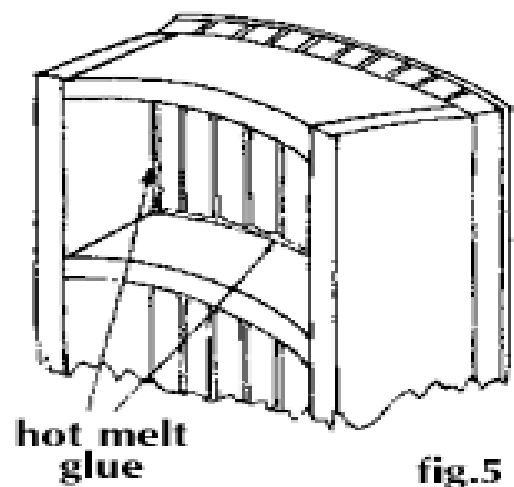
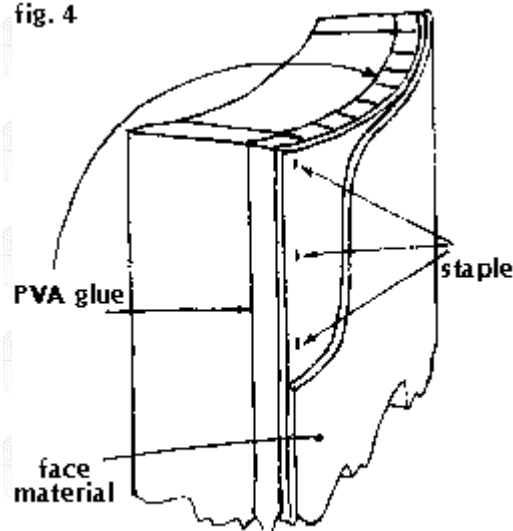

## Seaming Methods

*Vertical and horizontal seaming can be done in most any location*

The seam must be backed up with a vertical or horizontal rib. Timberflex and Flexboard should be glued and stapled in this location. If accessible, the use of a hot melt glue between the back of the material and the frame is recommended. (fig. 6)

**fig. 6**

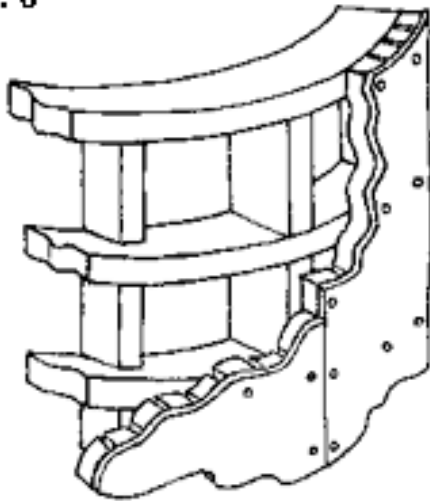

## Columns

*Timberflex is designed to bend to a 5" radius*

*Flexboard is designed to bend to a 10" radius. Keep in mind that the longer the column, the more difficult to bend the material and may require clamping to allow the glue and staples to hold sufficiently. In most cases it is recommended that half columns be constructed, as this will be easier to handle and fabricate. Two half columns can then be attached to form a whole column where needed.*

1. Cut horizontal ribs as needed. Recommended a horizontal support rib every 15 to 18 inches.
2. Vertical support rails should be attached the length of the column. Center support rails may be necessary to help form the column frame.
3. Timberflex or Flexboard should be cut to cover the framework. It is always best to use a narrow scrap piece to determine the correct width needed to wrap the column frame. This will allow for the thickness of the material being used and provide an accurate length measurement.

4. Apply glue to the framework ribs then position the Timberflex or Flexboard over it. Attach with a narrow crown staple by shooting through the face of the material and into the support ribs. It can be helpful to clamp the part in place while shooting the staples. These clamps can be removed once the Timberflex or Flexboard is securely attached to the framework. The use of rabbet and dado cuts into the back of the Timberflex or Flexboard can help in the location of the material to the framework.

5. If possible, it is recommended that some hot melt glue be applied on the inside of the framework to further provide a secure bond between the framework and the material.

6. Once the half column is formed, some edge trimming may be required to ensure that all edges are smooth and square.

7. Surface material may now be attached to the outer surface of the column with contact adhesive and edges trimmed as necessary.

8. In the case of producing a whole column, a spline or biscuit joint can be machined to assemble the columns together. After this assembly is complete, the column can then be covered with the desired surface material.

(Fig. 7 and Fig. 8)

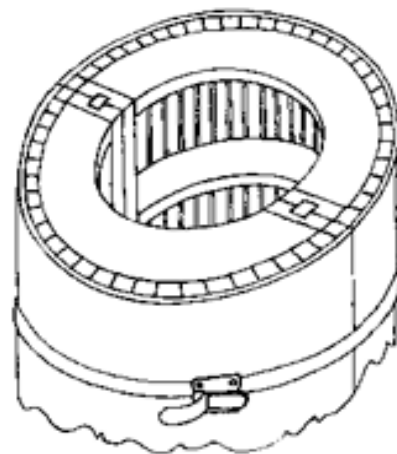
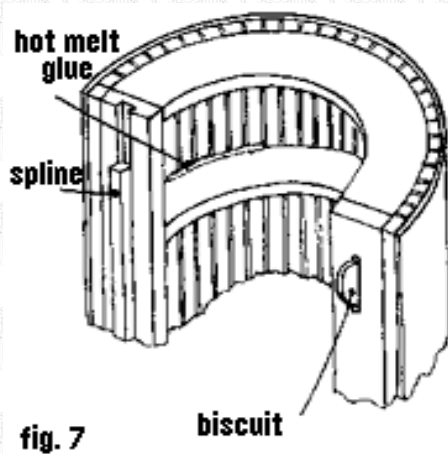

## **Timberflex and Flexboard Specifications**

### **Product Descriptions**

Timberflex is a flexible product designed for use in numerous kinds of radius projects. It consists of a core of kerfed particleboard with a 1/8" thick poplar plywood face.

Flexboard is a flexible product designed for use in numerous kinds of radius projects. It consists of a core of kerfed particleboard with a .080 thick hardboard face.

### **Product Characteristics**

Timberflex and Flexboard are flexible products that can be easily bent and attached to a ribbed frame by the use of nails or staples. Timberflex and Flexboard require two or three horizontal ribs as this equalizes the bending stresses and will produce a smooth finish surface.

Normal application involves the forming of Timberflex or Flexboard to a rigid structure and then the attachment of a face grade veneer or HPL by the use of contact adhesive.

Do not attach veneer or HPL prior to bending, especially on Timberflex.

### **Temperature Conditioning**

Timberflex and Flexboard should be acclimated the same as the face materials that will be applied to it. If available, use the guidelines recommended by the face material manufacturer.

### **Bending Capabilities**

The recommended bending radius obtainable using Timberflex is 5 inches. While a smaller radius may be obtainable, it is best to do a test before proceeding.

The recommended bending radius obtainable using Flexboard is 10 inches. In most applications a radius of 16 inches should be obtainable when applying a veneer prior to bending. While a smaller radius may be obtainable, it is best to do a test before proceeding.

### **Adhesives**

Any contact cement recommended for use with decorative laminates should be acceptable. Use of PVA glue is also acceptable for attaching face material provided they can be used after the Timberflex or Flexboard has been formed. As with any product, it is best to do a test on a small sample to determine how the materials will work together.

The kerfed core material can be formed and held in position with the use of most any adhesive and staples when necessary. The use of horizontal ribs for attachment is preferred, as this will provide the best support to allow the material to achieve the smoothest radius possible.

### **Laminating Pressure**

Timberflex or Flexboard - When using contact adhesive, light to moderate pressure is adequate. Firm hand pressure or moderate pressure with a J-roller works well. When using a PVA glue, make sure the glue is transferred to both materials and that adequate uniform pressure can be applied for the required amount of time.

Flexboard - Due to the stable hardboard face on Flexboard, it is possible to laminate a single ply veneer or a paperback veneer directly to the hardboard. Apply with a pressure of at least 100 psi. Urea resin based glues or hot pressing is not recommended as they will cause the face material to become too brittle and will crack upon flexing. When using this process, the recommended bending radius is reduced to 16". It is best to first perform a test on the process you plan to use prior to starting your project.

### **Handling**

Care should be taken in handling all materials. When moving either material be careful to pick up in such a manner as to not pinch fingers between the ribs. Try to not over flex the material or bend it past the recommended radius when handling.

### **Storage**

All products should be stored flat with the face material side facing up. Keep in a dry area and away from direct contact with the floor to allow for air circulation.